

Brake Motor 150W (□90mm)

150W Brake Motor 150W(□90mm)

Motor Specification

| Model 9BDG*-150F□: Gear Type Shaft 9BDD*-150F: D-Cut Type Shaft 9BDK*-150F: Key Type Shaft | Output W | Voltage V | Frequency Hz | Poles | Duty | Starting Torque | | Rated Load | | | Capacitor μF / VAC | |
|---|-------------|--------------|-----------------|-------|-------|-----------------|-------|----------------|--------------|---------------------|-----------------------|---|
| | | | | | | kgfcm | N.m | Speed r/min | Current A | Torque kgfcm N.m | | |
| 9BDGG-150F□ | 150 | 3∅220 | 50 | 4 | Cont. | 22.00 | 2,200 | 1300 | 1.00 | 11.30 | 1,130 | - |
| | | | 60 | | | 19.00 | 1,900 | 1550 | 0.90 | 9.40 | 0,940 | |
| 9BDGK-150F□ | 150 | 3∅380 | 50 | 4 | Cont. | 18.00 | 1,800 | 1250 | 0.46 | 11.70 | 1,170 | - |
| | | | 60 | | | 15.00 | 1,500 | 1500 | 0.42 | 9.70 | 0,970 | |
| | | 3∅400 | 50 | 4 | Cont. | 19.00 | 1,900 | 1250 | 0.49 | 11.70 | 1,170 | |
| | | | 60 | | | 16.00 | 1,600 | 1500 | 0.43 | 9.70 | 0,970 | |

- 1) Enter the phase & voltage code in the place * and enter the model type of attaching Gearbox in the box (□) within the motor model name.
- 2) All models contain a built-in thermal protector.
- 3) Gear Type Shaft is for attaching Gearbox and D-Cut & Key Type Shafts are for using motor only.

Max. Permissible Torque at Output Shaft of Gearbox

60Hz

| Motor Model | Gearbox Model | Gear Ratio r/min | 3 | 3.6 | 6 | 9 | 12.5 | 15 | 18 | 20 | 25 | 30 | 36 | 50 | 60 | 75 | 90 | 100 | 120 | 150 | 180 | 200 |
|-----------------|---------------|---------------------|------|------|------|------|------|-------|-------|-------|-------|-------|-------|-------|-------|-------|-------|-------|-------|-------|-------|-------|
| | | | 600 | 500 | 300 | 200 | 144 | 120 | 100 | 90 | 72 | 60 | 50 | 36 | 30 | 24 | 20 | 18 | 15 | 12 | 10 | 9 |
| 9BDG□ -150FH | 9HBK□BH | kgfcm | 24.2 | 29.0 | 48.3 | 72.5 | 90.9 | 109.1 | 131.0 | 131.9 | 164.9 | 197.9 | 237.5 | 300.0 | 300.0 | 300.0 | 300.0 | 300.0 | 300.0 | 300.0 | 300.0 | 300.0 |
| | 9HFK□BH | N.m | 2.37 | 2.84 | 4.73 | 7.10 | 8.91 | 10.69 | 12.83 | 12.93 | 16.16 | 19.39 | 23.27 | 29.40 | 29.40 | 29.40 | 29.40 | 29.40 | 29.40 | 29.40 | 29.40 | 29.40 |

| Motor Model | Gearbox Model | Gear Ratio r/min | 7.5 | 10 | 15 | 20 | 25 | 30 | 40 | 50 | 60 | 80 | 100 |
|------------------|---------------|---------------------|------|-------|-------|-------|-------|-------|-------|-------|-------|-------|-------|
| | | | 240 | 180 | 120 | 90 | 72 | 60 | 45 | 36 | 30 | 22.5 | 18 |
| 9BDG□ -150FWH | 9WHD□-030 | kgfcm | 61.1 | 78.6 | 110.6 | 139.7 | 160.1 | 186.2 | 183.7 | 173.5 | 163.3 | 132.7 | - |
| | N.m | 5.99 | 7.70 | 10.84 | 13.69 | 15.68 | 18.25 | 18.00 | 17.00 | 16.00 | 13.00 | - | |
| | 9WHD□-040 | kgfcm | - | - | - | - | - | - | - | 230.0 | 255.0 | 295.0 | 270.0 |
| | N.m | - | - | - | - | - | - | - | - | 22.55 | 25.00 | 28.92 | 26.47 |

50Hz

| Motor Model | Gearbox Model | Gear Ratio r/min | 3 | 3.6 | 6 | 9 | 12.5 | 15 | 18 | 20 | 25 | 30 | 36 | 50 | 60 | 75 | 90 | 100 | 120 | 150 | 180 | 200 |
|-----------------|---------------|---------------------|------|------|------|------|-------|-------|-------|-------|-------|-------|-------|-------|-------|-------|-------|-------|-------|-------|-------|-------|
| | | | 500 | 417 | 250 | 167 | 120 | 100 | 83 | 75 | 60 | 50 | 42 | 30 | 25 | 20 | 17 | 15 | 13 | 10 | 8 | 7.5 |
| 9BDG□ -150FH | 9HBK□BH | kgfcm | 28.1 | 33.8 | 56.3 | 84.4 | 105.9 | 127.1 | 152.6 | 153.7 | 192.1 | 230.5 | 276.6 | 300.0 | 300.0 | 300.0 | 300.0 | 300.0 | 300.0 | 300.0 | 300.0 | 300.0 |
| | 9HFK□BH | N.m | 2.76 | 3.31 | 5.51 | 8.27 | 10.38 | 12.46 | 14.95 | 15.06 | 18.83 | 22.59 | 27.11 | 29.40 | 29.40 | 29.40 | 29.40 | 29.40 | 29.40 | 29.40 | 29.40 | 29.40 |

| Motor Model | Gearbox Model | Gear Ratio r/min | 7.5 | 10 | 15 | 20 | 25 | 30 | 40 | 50 | 60 | 80 | 100 |
|------------------|---------------|---------------------|------|-------|-------|-------|-------|-------|-------|-------|-------|-------|-------|
| | | | 200 | 150 | 100 | 75 | 60 | 50 | 37.5 | 30 | 25 | 18.75 | 15 |
| 9BDG□ -150FWH | 9WHD□-030 | kgfcm | 71.2 | 91.5 | 128.8 | 162.7 | 186.5 | 204.1 | 183.7 | 173.5 | 163.3 | 132.7 | - |
| | N.m | 6.98 | 8.97 | 12.62 | 15.95 | 18.28 | 20.00 | 18.00 | 17.00 | 16.00 | 13.00 | - | |
| | 9WHD□-040 | kgfcm | - | - | - | - | - | - | - | 275.0 | 305.0 | 295.0 | 270.0 |
| | N.m | - | - | - | - | - | - | - | - | 26.96 | 29.90 | 28.92 | 26.47 |

- 1) Enter the phase & voltage code in the box (□) within the motor model name.
- 2) Enter the gear ratio in the box (□) within the Gearbox model name.
- 3) A colored background indicates gear shaft rotation in the same direction as the motor shaft; a white background indicates rotation in the opposite direction.
- 4) The rotating speed is calculated by dividing the motor's synchronous speed (50Hz: 1,500r/min, 60Hz: 1,800r/min) by the gear ratio.
The actual speed is 2~20% less than the displayed value, depending on the size of the load.

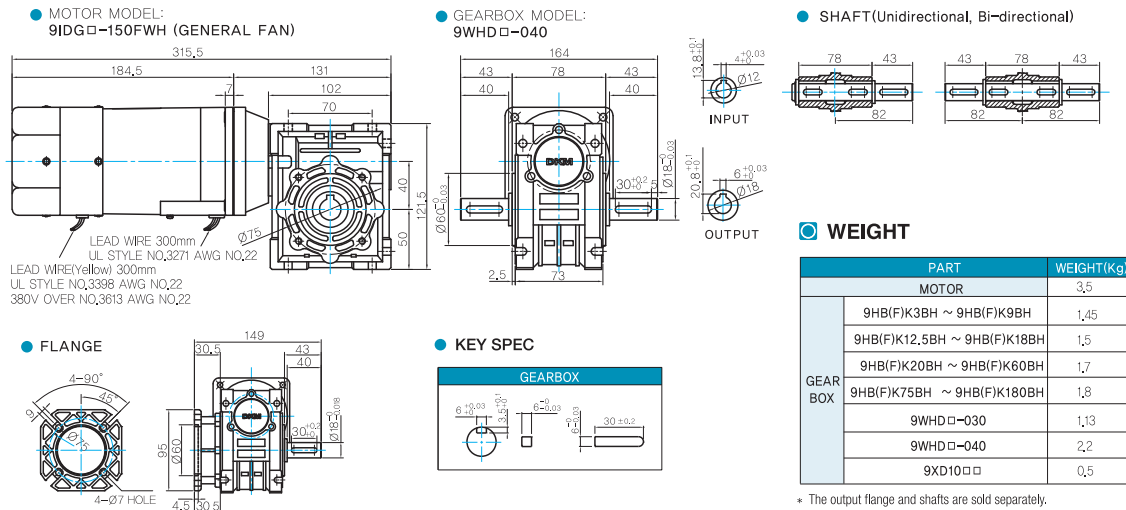

Connection Diagrams

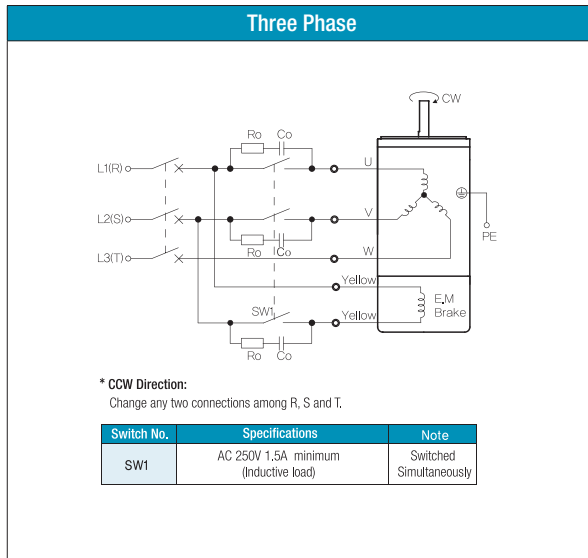

Motor Images



- The direction of motor rotation is as viewed from the shaft end of the motor.
- CW represents the clockwise direction, while CCW represents the counterclockwise direction.
- SW1 operates both motor and electromagnetic brake action.
- The electromagnetic brake will be released and the motor will rotate when SW1 is switched simultaneously to ON.
When SW1 is switched simultaneously to OFF,
the motor stops immediately with the electromagnetic brake and holds the load.
- If you wish to release the brake while the motor is stopped, apply voltage between the two brake lead wires (yellow).
- Ro and Co indicate CR circuit for surge suppression. [Ro=5~200Ω, Co=0.1~0.2μF, 200WV (400WV)]