

# B AC Motors

S.C. C&B Motor 90W (□90mm)

## 90W Speed Control Clutch & Brake Motor 90W(□90mm)

### Motor Specification

Model 9CSDG□-90F2P: Gear Type Shaft	Output W	Voltage V	Frequency Hz	Poles	Duty	Speed Range r/min	Starting Torque		Permissible Torque				Capacitor μF / VAC
							kgfcm	N.m	1200r/min		90r/min		
									kgfcm	N.m	kgfcm	N.m	
9CSDGA-90F2P	90	1φ110	60	4	Cont.	90-1700	6.50	0.650	6.30	0.630	3.00	0.300	20.0 / 250
9CSDGD-90F2P	90	1φ220	60	4	Cont.	90-1700	6.50	0.650	6.30	0.630	3.00	0.300	5.0 / 400
9CSDGE-90F2P	90	1φ220	50	4	Cont.	90-1400	4.60	0.460	5.40	0.540	2.20	0.220	5.0 / 400
		5.50					0.550	6.10	0.610	2.20	0.220		

- 1) Enter the phase & voltage code in the box (□) within the motor model name.
- 2) All models contain a built-in thermal protector.
- 3) For using clutch & brake motor, Gearbox has to be attached. (Output shaft of motor: Gear Type Shaft)

### Max. Permissible Torque at Output Shaft of Gearbox

Motor Model	Gearbox Model	r/min	V	Hz	Gear Ratio	2	3	3.6	5	6	7.5	9	12.5	15	18	20	25	30	36	40	50	60	75	90	100	120	150	180	200					
9CSDG □ -90F2P	9PBK □BH 9PFK □BH	1200	110	60	kgfcm N.m	10.5 1.02	15.7 1.54	18.8 1.84	26.1 2.56	31.4 3.07	39.2 3.84	47.1 4.61	59.1 5.79	70.9 6.95	85.1 8.33	85.7 8.40	107.1 10.50	128.5 12.59	154.2 15.11	171.4 16.79	200.0 19.60	200.0 19.60	200.0 19.60	200.0 19.60	200.0 19.60	200.0 19.60	200.0 19.60	200.0 19.60	200.0 19.60					
						220/240	10.5 1.02	15.7 1.54	18.8 1.84	26.1 2.56	31.4 3.07	39.2 3.84	47.1 4.61	59.1 5.79	70.9 6.95	85.1 8.33	85.7 8.40	107.1 10.50	128.5 12.59	154.2 15.11	171.4 16.79	200.0 19.60	200.0 19.60	200.0 19.60	200.0 19.60	200.0 19.60	200.0 19.60	200.0 19.60	200.0 19.60	200.0 19.60	200.0 19.60	200.0 19.60	200.0 19.60	
						90	kgfcm N.m	5.0 0.49	7.5 0.73	9.0 0.88	12.5 1.22	14.9 1.46	18.7 1.83	22.4 2.20	27.6 2.76	33.1 3.31	39.7 3.97	40.5 4.00	51.0 5.00	61.2 6.00	73.4 7.20	81.6 8.00	102.0 10.00	122.4 12.00	137.3 13.45	164.7 16.14	183.0 17.93	200.0 19.60	200.0 19.60	200.0 19.60	200.0 19.60	200.0 19.60	200.0 19.60	200.0 19.60
								220/240	3.7 0.36	5.5 0.54	6.6 0.64	9.1 0.89	11.0 1.07	13.7 1.34	16.4 1.61	20.6 2.02	24.8 2.43	29.7 2.91	29.9 2.93	37.4 3.67	44.9 4.40	53.9 5.28	59.8 5.86	74.8 7.33	89.8 8.80	100.7 9.86	120.8 11.84	134.2 13.15	161.0 15.78	200.0 19.60	200.0 19.60	200.0 19.60	200.0 19.60	200.0 19.60

- 1) Enter the phase & voltage code in the box (□) within the motor model name.
- 2) Enter the gear ratio in the box (□) within the Gearbox model name.
- 3) A colored background indicates gear shaft rotation in the same direction as the motor shaft; a white background indicates rotation in the opposite direction.
- 4) The rotating speed is calculated by dividing the motor's synchronous speed (50Hz: 1,500r/min, 60Hz: 1,800r/min) by the gear ratio.  
The actual speed is 2~20% less than the displayed value, depending on the size of the load.

### Dimensions

#### GEARED MOTOR

#### P TYPE GEARBOX

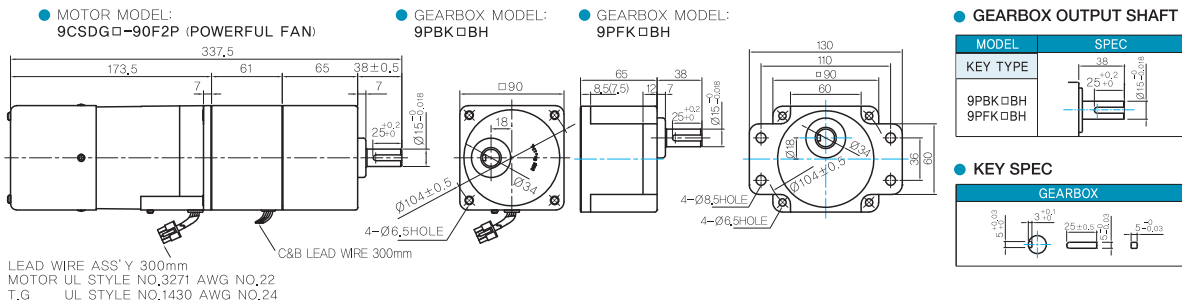

### INTER-DECIMAL GEARBOX

● MODEL:  
9XD10□□

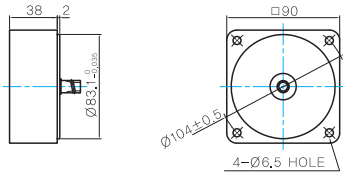

### WEIGHT

PART	WEIGHT(Kg)	
MOTOR	3,0	
CLUTCH & BRAKE	1,35	
GEAR BOX	9PB(F)K2BH - 9PB(F)K18BH	1,3
	9PB(F)K20BH - 9PB(F)K200B	1,4
9XD10□□	0,5	

### Motor Images

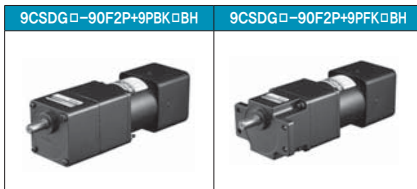

### Connection Diagrams

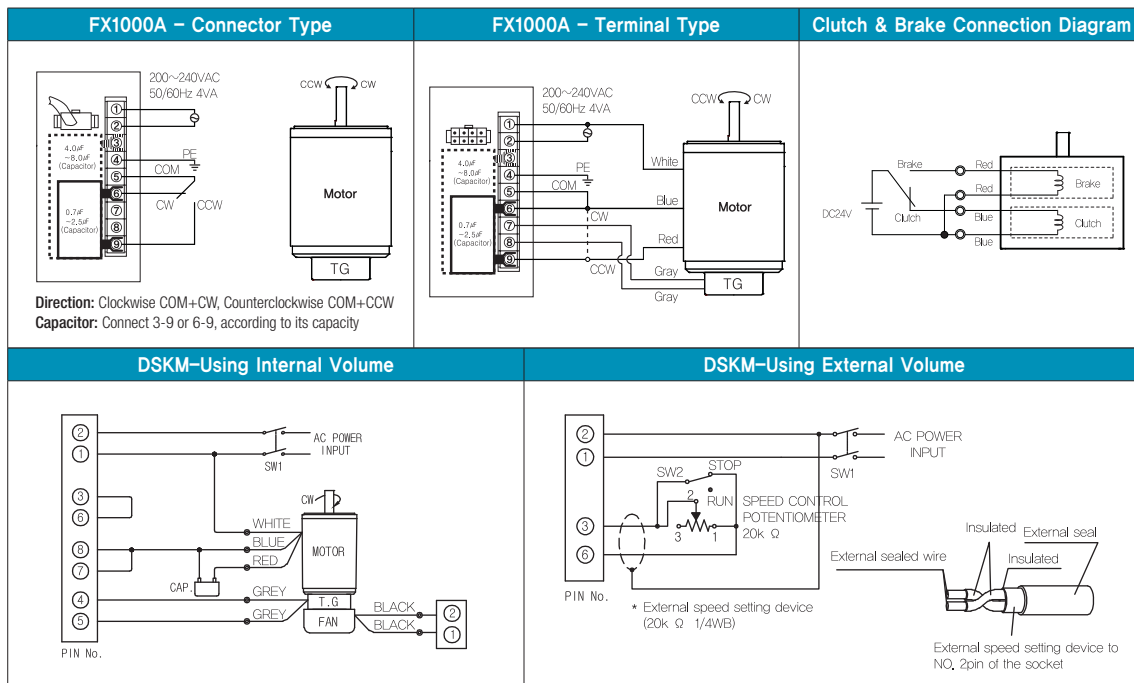

1) At first connect the speed controller with the motor as instructed in connection diagrams. And then input the external power to both of the terminal 'AC' for the rated speed operation.

Now you can adjust the main volume to control the output speed of motor.

2) The direction of motor rotation is as viewed from the shaft end of the motor.

3) CW represents the clockwise direction, while CCW represents the counterclockwise direction.

4) When using powerful fan (F2 type) attached motor, connect two black wires of the fan to No.1 and No.2 terminals in order to supply power.